

24VDC OPERATION

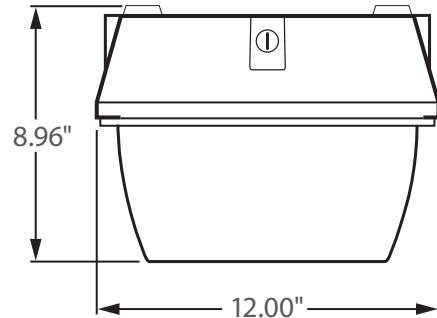

Incredible OFF GRID Operation

GENERAL DESCRIPTION

Neptun's 12" square Induction canopy fixture features classic design and durability to be used in new construction or retrofit applications. The 12 series canopy fixture features excellent optics for increased visibility and security with horizontal and vertical footcandles to evenly illuminate parking garages. The 24 Volt DC driver allows for compatible use with Solar or Wind powered systems. It can replace existing HID canopy or parking garage fixtures up to 200 Watts.

APPLICATION

- Solar Parking Garage Lighting
- Solar Canopy Lighting
- Solar Gas Station Lighting
- Solar Indoor Lighting
- Solar Storage Lighting
- Solar Security Lighting
- Solar Area Lighting

STRUCTURE, MATERIALS, & FEATURES

- Heavy-gauge, die-cast aluminum housing.
- High efficiency, heat and impact resistant, UV protected, non yellowing polycarbonate lens / refractor.
- Custom designed anodized aluminum reflectors for superior illuminance.
- Corrosion resistant electrocoat dark bronze finish (custom colors available).
- Easy removal lens with (4) stainless steel screws.
- Continuous silicone gasketing surrounds lens for weather - tight seal.
- Inductively coupled circular induction bulb.
- High power factor, 24 Volt DC ballast.
- Instant-On flicker-free Cold Start and Hot Re-Start.
- High quality glare-free light with high CRI above (83).
- Bright white light (5000°K) for greater visibility and safety.
- Advance phosphors for high lumen output and high lumen maintenance.
- Up to 20 year maintenance free operation.
- 10 Year Warranty.

ORDERING INFORMATION

Sample Number: 12040-24VDC-850-LD-BRZ
 Custom options and accessories available. Please consult factory

Series	Lamp Wattage	Voltage	Color Temp	Accessories	Color
12 = 12" Square Canopy	040 = 40 W 080 = 80 W 100 = 100 W	24VDC = 24 VDC	830 = 3000°K 841 = 4100°K 850 = 5000°K * * Standard	LD = Light Detector / Photocell MD = Motion Sensor Detector	BRZ = Dark Bronze * Custom Colors Available



PRODUCT INFORMATION

Model No.	Description	Rated Watts	Input Watts	Initial Lumens	Input Line Voltage (VDC)	Max Line Current (Amp)	Power Factor	Weight
12040-24VDC	12" Square Canopy	40	41	3,200	24	1.74	0.98	10 lbs
12080-24VDC	12" Square Canopy	80	82	6,400	24	3.49	0.98	12 lbs
12100-24VDC	12" Square Canopy	100	105	8,000	24	4.37	0.98	12 lbs

SPECIFICATIONS

- Ballast Type Electronic
- Start Method InstantON
- Hot Re-start InstantON
- Input Line Voltage 24 VDC
- Input Line Frequency 50/60 Hz
- Lamp Operating Frequency 250 kHz
- Ballast Off-State Draw 0 Watts
- Sound Rating Class A
- Lamp / Ballast System Life 100,000 Hrs.
- Lumen Maintenance @75,000Hrs > 70%
- Color Temperature 5000°K
- Color Rendering Index (CRI) > 83
- Minimum Starting Temperature -20°F
- Maximum Starting Temperature 160°F
- Initial Lumens per Watt 80
- Shock / Vibration Resistant Yes
- Power Factor > 0.98
- ETL Listed / UL Standard 1598 Yes
- FCC Compliance Part 18, Subp. C
- IP Rating IP65
- Warranty 10 Year

MOUNTING OPTIONS

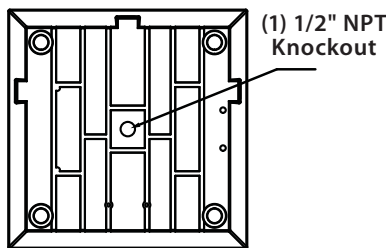

Pendant Mount

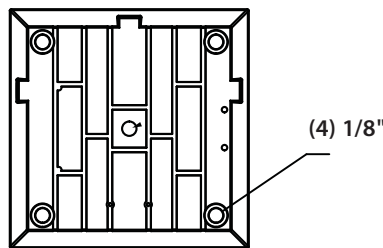

Surface Mount

PHOTOMETRICS (See Complete IES File)

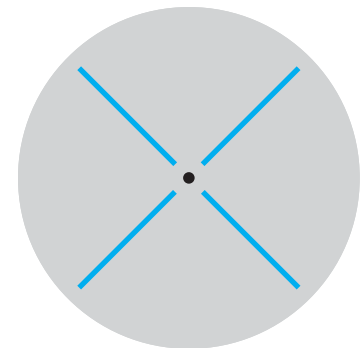

Type V Distribution

Neptun Light, Inc.
 13950 Business Center Drive
 Lake Forest, IL 60045
 Fax: 847.735.8004

Neptun Light, Inc. reserves the right to change materials or modify the design of its product without notification as part of the company's continuing product improvement program.
 ©2002-2013 Neptun Light, Inc. All rights reserved.

Spec. Rev. 1-2013