

Incredible **100,000 hrs**

### GENERAL DESCRIPTION

Neptun's 15" cone Induction canopy fixture features classic design and durability to be used in new construction or retrofit applications. The 13 series canopy fixture features excellent optics for increased visibility and security with horizontal and vertical footcandles to evenly illuminate parking garages. It can replace existing HID & HPS canopy or parking garage fixtures up to 250 Watts.

### APPLICATION

- Parking Garage Lighting
- Canopy Lighting
- Gas Station Lighting
- Indoor Lighting
- Storage Lighting
- Security Lighting
- Area Lighting

### STRUCTURE, MATERIALS, & FEATURES

- Heavy-gauge, die-cast aluminum housing.
- High efficiency, heat and impact resistant, UV protected, non yellowing polycarbonate lens / refractor.
- Custom designed anodized aluminum reflectors for superior illuminance.
- Corrosion resistant electrocoat dark bronze finish (custom colors available).
- Easy removal lens with (4) stainless steel screws.
- Continuous silicone gasketing surrounds lens for weather - tight seal.
- Inductively coupled circular induction bulb.
- High power factor, low THD electronic ballast with surge protection.
- Instant-On flicker-free Cold Start and Hot Re-Start.
- High quality glare-free light with high CRI above (83).
- Bright white light (5000°K) for greater visibility and safety.
- Advance phosphors for high lumen output and high lumen maintenance.
- Up to 20 year maintenance free operation with 10 Year Warranty.
- **Optional:** DC 24V Operation - Solar Compatible

### ORDERING INFORMATION

Sample Number: 13040-UNV-850-MD-BRZ  
 Custom options and accessories available. Please consult factory

Series	Wattage	Voltage	Color Temp	Accessories	Color
13 = 15" Conical Canopy	040 = 40 W 080 = 80 W 100 = 100 W 120 = 120 W	UNV = 120-277 VAC 347V = 347 VAC 480V = 480 VAC 24VDC = 24V DC * * only available up to 100w	830 = 3000°K 841 = 4100°K 850 = 5000°K * * Standard	LD-120V = Photocell -120V LD-277V = Photocell - 277V MD = Motion Sensor	BRZ = Dark Bronze * Custom Colors Available



lightinnovations@work™

### PRODUCT INFORMATION

Model No.	Description	Rated Watts	Input Watts	Initial Lumens	Universal Line Voltage (VAC)	Max Line Current (Amp) @ 120 - 277	THD	Power Factor	Weight
13040-UNV	15" Cone Canopy Fixture	40	41	3,200	120-277	0.35-0.15	<10%	0.98	8 lbs
13080-UNV	15" Cone Canopy Fixture	80	82	6,400	120-277	0.69-0.30	<10%	0.98	10 lbs
13100-UNV	15" Cone Canopy Fixture	100	105	8,000	120-277	0.87-0.37	<10%	0.98	10 lbs
13120-UNV	15" Cone Canopy Fixture	120	125	9,600	120-277	1.05-0.45	<10%	0.98	10 lbs

### SPECIFICATIONS

- Ballast Type ..... Electronic
- Start Method ..... InstantON
- Hot Re-start ..... InstantON
- Universal Input Line Voltage ..... 120-277 VAC
- Input Line Frequency ..... 50/60 Hz
- Lamp Operating Frequency ..... 250 kHz
- Ballast Off-State Draw ..... 0 Watts
- Sound Rating ..... Class A
- ANSI Surge Protection ..... Class A
- Lamp / Ballast System Life ..... 100,000 Hrs.
- Lumen Maintenance @75,000Hrs ..... > 70%
- Color Temperature ..... 5000°K
- Color Rendering Index (CRI) ..... 83
- Minimum Starting Temperature ..... -20°F
- Maximum Starting Temperature ..... 160°F
- Lumens per Watt ..... 80
- Shock / Vibration Resistant ..... Yes
- Power Factor ..... > 0.98
- Total Harmonic Distortion ..... < 10%
- Inrush Current Peak ..... < 10 Amp
- ETL Listed / UL Standard 1598 ..... Yes
- FCC Compliance ..... Part 18, Subp. C
- IP Rating ..... IP65
- Warranty ..... 10 Year

### MOUNTING OPTIONS

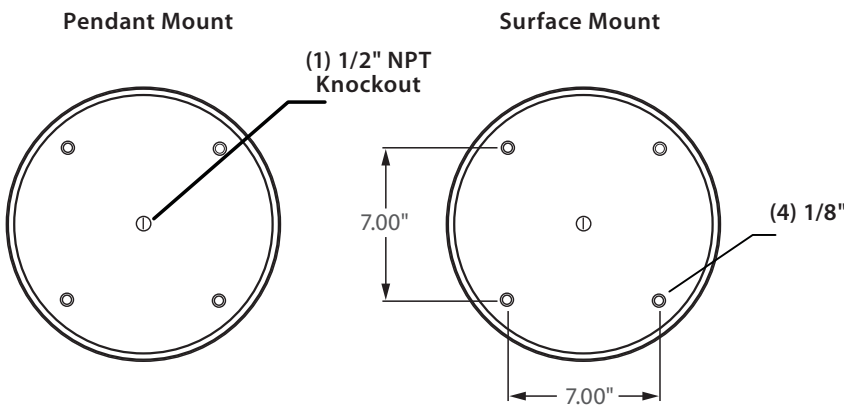

### PHOTOMETRICS (See Complete IES File)

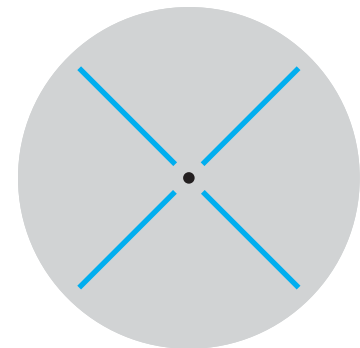

Type V Distribution

Neptun Light, Inc.  
13950 Business Center Drive  
Lake Forest, IL 60045  
Fax: 847.735.8004

Neptun Light, Inc. reserves the right to change materials or modify the design of its product without notification as part of the company's continuing product improvement program.  
©2002-2016 Neptun Light, Inc. All rights reserved. Spec. Rev. 4-2016