

Incredible **100,000 hrs**

### GENERAL DESCRIPTION

Neptun's Semi Cut-Off Wall Pack fixtures feature classic form and durability to make it an excellent choice for new construction or retrofit applications. Neptun's 11 series Wall Pack fixtures feature a high CRI and bright white 5000°K color temperature for increased safety and security. They can replace existing HID & HPS fixtures up to 100 Watts.

### APPLICATION

- Building Accent Lighting
- Landscape Lighting
- Doorway Lighting
- Security Lighting
- Area Lighting

### STRUCTURE, MATERIALS, & FEATURES

- Heavy-gauge, die-cast aluminum housing.
- Custom designed anodized aluminum reflectors for superior illuminance.
- Heat and impact resistant, UV protected, non yellowing polycarbonate refractor / lens.
- Corrosion resistant electrocoat dark bronze finish (custom colors available).
- Hinged aluminum door frame incorporates stainless steel hardware.
- Continuous silicone gasketing surrounds lens for weather - tight seal.
- Inductively coupled rectangular induction bulb.
- High power factor, low THD electronic ballast with surge protection.
- Instant-On flicker-free Cold Start and Hot Re-Start.
- High quality glare-free light with high CRI above (83).
- Bright white light (5000°K) for greater visibility and safety.
- Advance phosphors for high lumen output and high lumen maintenance.
- Up to 20 year maintenance free operation.
- 10 Year Warranty.
- **Optional:** DC 24V Operation - Solar Compatible

### ORDERING INFORMATION

Sample Number: 11040SCT-UNV-850-LD-120V-BRZ  
 Custom options and accessories available. Please consult factory

Series	Wattage	Lens Type	Voltage	Color Temp	Accessories	Color
11 = Wall Pack	040 = 40 W	SCT = Semi Cut-Off	UNV = 120-277 VAC 24VDC = 24V DC	830 = 3000°K 841 = 4100°K 850 = 5000°K* * Standard	LD-120V = Photocell for 120V LD-277V = Photocell for 277V	BRZ = Dark Bronze * Custom Colors Available



lightinnovations@work™

### PRODUCT INFORMATION

Model No.	Description	Rated Watts	Input Watts	Initial Lumens	Universal Line Voltage (VAC)	Max Line Current (Amp) @ 120 - 277	THD	Power Factor	Weight
11040SCT-UNV	Wall Pack - Semi Cut-Off	40	41	3,200	120-277	0.35-0.15	<10%	0.98	8 lbs

### SPECIFICATIONS

- Ballast Type ..... Electronic
- Start Method ..... InstantON
- Hot Re-start ..... InstantON
- Universal Input Line Voltage ..... 120-277 VAC
- Input Line Frequency ..... 50/60 Hz
- Lamp Operating Frequency ..... 250 kHz
- Ballast Off-State Draw ..... 0 Watts
- Sound Rating ..... Class A
- ANSI Surge Protection ..... Class A
- Lamp / Ballast System Life ..... 100,000 Hrs.
- Lumen Maintenance @75,000Hrs ..... > 70%
- Color Temperature ..... 5000°K
- Color Rendering Index (CRI) ..... 83
- Minimum Starting Temperature ..... -20°F
- Maximum Starting Temperature ..... 160°F
- Lumens per Watt ..... 80
- Shock / Vibration Resistant ..... Yes
- Power Factor ..... > 0.98
- Total Harmonic Distortion ..... < 10%
- Inrush Current Peak ..... < 10 Amp
- ETL Listed / UL Standard 1598 ..... Yes
- FCC Compliance ..... Part 18, Subp. C
- IP Rating ..... IP65
- Warranty ..... 10 Year

### MOUNTING OPTIONS

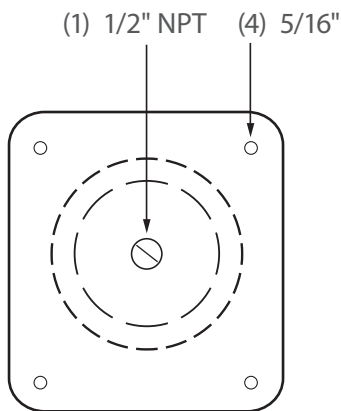

### PHOTOMETRICS (See Complete IES File)

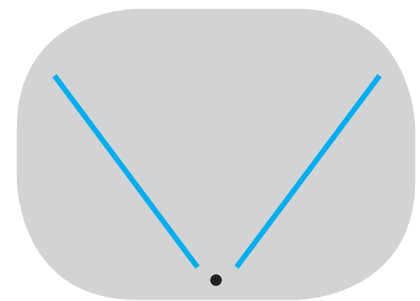

Type IV Distribution

Neptun Light, Inc.  
 13950 Business Center Drive  
 Lake Forest, IL 60045  
 Fax: 847.735.8004

Neptun Light, Inc. reserves the right to change materials or modify the design of its product without notification as part of the company's continuing product improvement program.  
 ©2002-2016 Neptun Light, Inc. All rights reserved. Spec. Rev. 4-2016