

REMOVING EXISTING BALLAST

- A.) **DISCONNECT POWER TO FIXTURE**
- B.) Remove existing fluorescent tubes and properly recycle.
- C.) Locate the existing ballast inside the fixture
- D.) Cut existing wires from ballast to fixture and ballast to power. (Cut wires near ballast to ensure proper length).
- E.) Remove ballast and properly recycle.

INSTALLING LED LAMPS (see wiring diagram on Pg. 2)

- A.) Reconnect existing wires directly to the power source.
- B.) Reassemble ballast cover.
- C.) Insert Neptun LED T8 Lamps into existing sockets.
- D.) Resupply power to fixture.

1. Remove Electronic Ballast



2. Connect Wiring

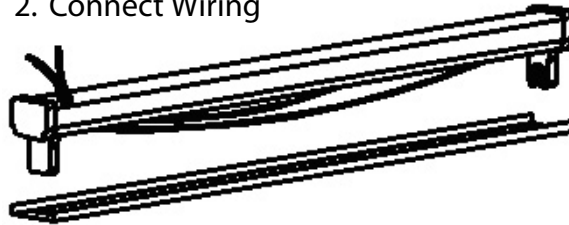

3. Install LED Tube

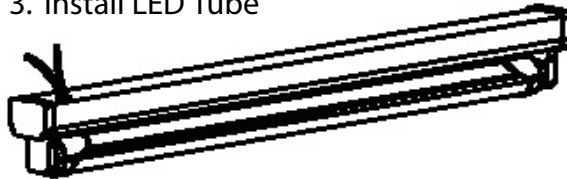

NOTE:

Neptun LED Tubes are suitable for all socket types



NON-SHUNTED

SHUNTED W/ JUMPER

CAUTION!

DISCONNECT POWER SUPPLY BEFORE INSTALLATION OR MAINTENANCE.
INSTALLATION OF THIS PRODUCT SHOULD BE DONE BY A FULLY QUALIFIED AND
LICENSED ELECTRICIAN OR TECHNICIAN.

INSTALLATION INSTRUCTIONS

UBT8/NUBT8 88000-LED SERIES - T8 U-BEND (2 Pole) (Operate on 120-277 VAC)

Wiring Diagram: Rapid Start - 1 Lamp System

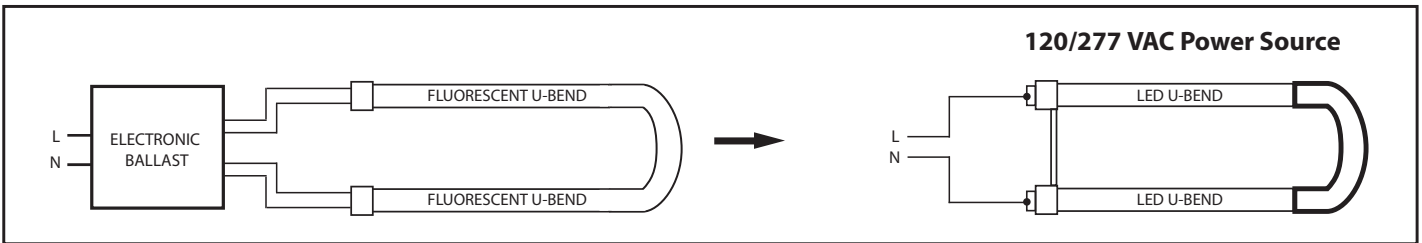

Wiring Diagram: Rapid Start - 2 Lamp System

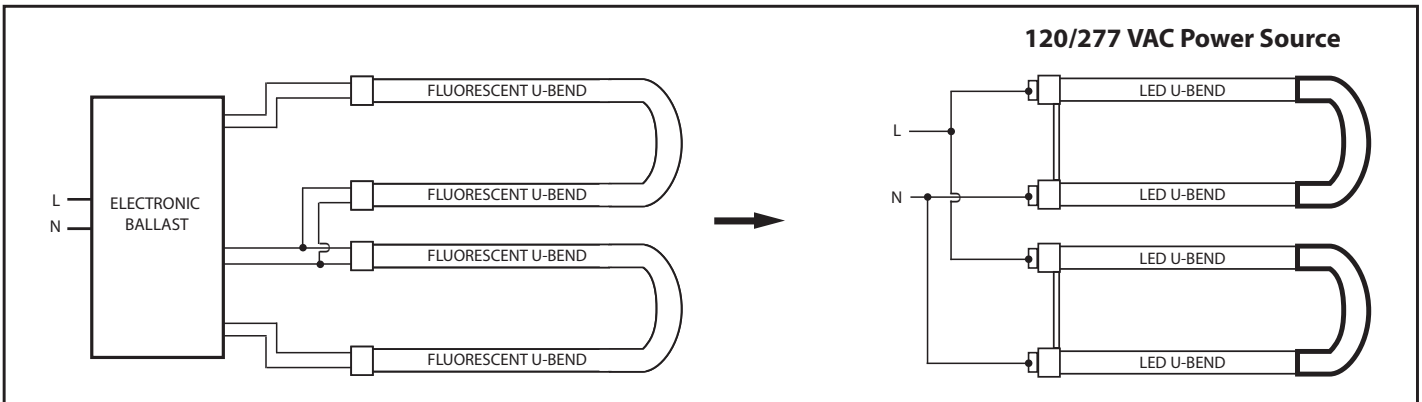

Wiring Diagram: Instant Start - 1 Lamp System w/ Shunted or Jumper Tombstone

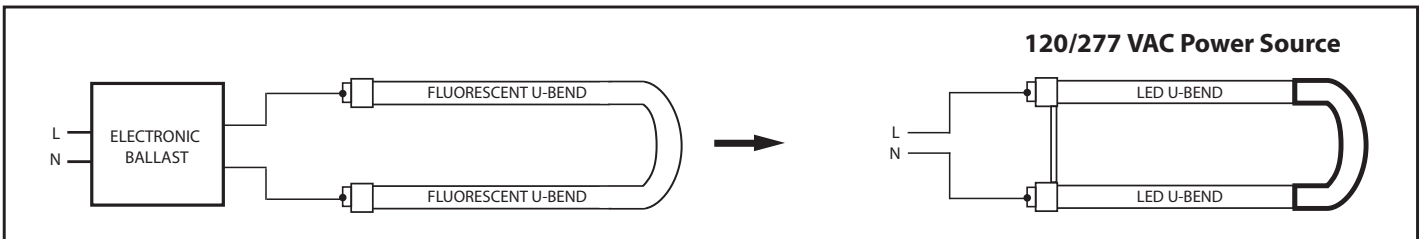

Wiring Diagram: Instant Start - 1 Lamp System w/ Shunted or Jumper Tombstone

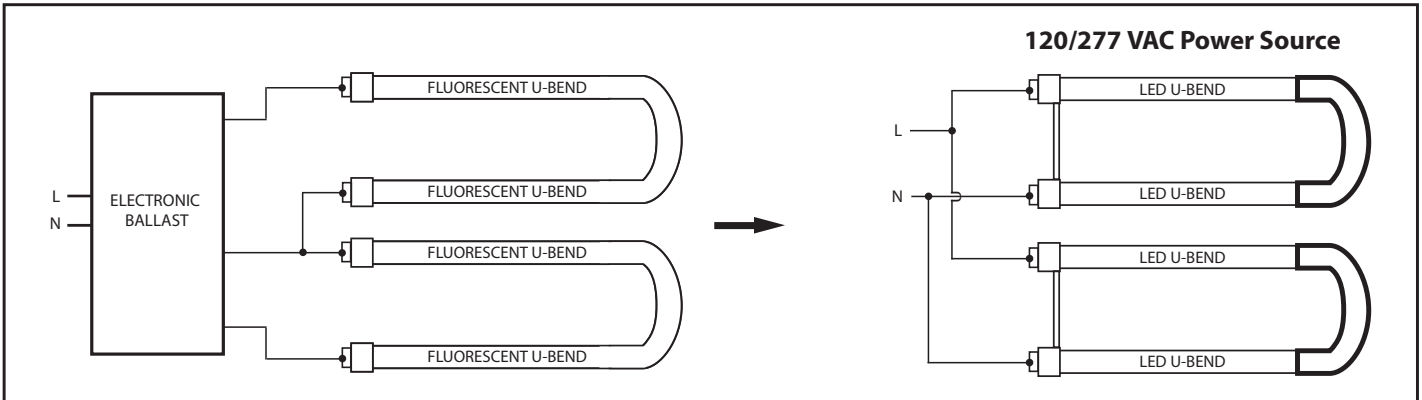

NEPTUN Light, Inc.
 Questions and Comments:
service@neptunlight.com
 Toll-Free: 1-888-735-8330

© Copyright 2012
 NEPTUN Light, Inc.

CAUTION!

DISCONNECT POWER SUPPLY BEFORE INSTALLATION OR MAINTENANCE.
 INSTALLATION OF THIS PRODUCT SHOULD BE DONE BY A FULLY QUALIFIED AND
 LICENSED ELECTRICIAN OR TECHNICIAN.