

24VDC OPERATION

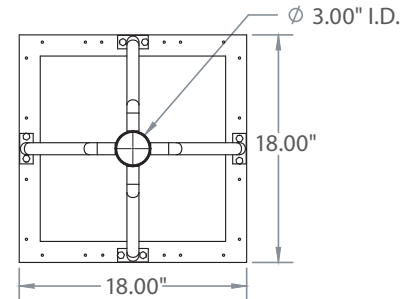
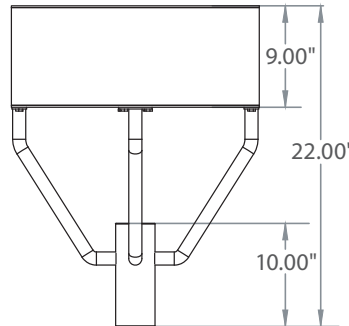

Incredible OFF GRID Operation

GENERAL DESCRIPTION

Neptun's 18" Induction Square Post-Top fixture combines classic form and versatility to make it an excellent choice for new construction or retrofit applications. The 64 series square post-top fixture is offered in a variety of wattages to provide maximum flexibility in all types of applications. The 24 Volt DC driver allows for compatible use with Solar or Wind powered systems. It can replace existing HID fixtures up to 400W.

APPLICATION

- Parking Lot Lighting
- Car Lot Lighting
- Area & Storage Lighting
- Street Lighting
- Walkway Lighting

STRUCTURE, MATERIALS, & FEATURES

- Heavy-gauge, die-cast aluminum housing.
- Custom designed anodized aluminum reflectors for superior illuminance.
- Heat and impact resistant tempered flat glass lens. (IESNA full-cutoff)
- 3" I.D. Slip Fitter Accepts up to 2-7/8" Pipe or Tenon. (hardware included)
- Corrosion resistant electrocoat dark bronze finish. (custom colors available)
- Aluminum door frame incorporates stainless steel hardware.
- Continuous silicone gasketing surrounds lens for weather - tight seal.
- Inductively coupled circular induction bulb.
- High power factor, 24 Volt DC ballast.
- Instant-On flicker-free Cold Start and Hot Re-Start.
- High quality glare-free light with high CRI above (83).
- Bright white light (5000°K) for greater visibility and safety.
- Advance phosphors for high lumen output and high lumen maintenance.
- Up to 20 year maintenance free operation.
- 10 Year Warranty.

ORDERING INFORMATION

Sample Number: 64080-24VDC-850-LD-BRZ
 Custom options and accessories available. Please consult factory

Series	Lamp Wattage	Voltage	Color Temp	Accessories	Color
64 = Square Pot-Top	080 = 80 W 100 = 100 W 120 = 120 W 150 = 150 W	24VDC = 24 VDC	830 = 3000°K 841 = 4100°K 850 = 5000°K * * Standard	LD = Light Sensor /Photocell MD = Motion Sensor Detector	BRZ = Dark Bronze * Custom Colors Available



PRODUCT INFORMATION

Model No.	Description	Rated Watts	Input Watts	Initial Lumens	Input Line Voltage (VDC)	Max Line Current (Amp)	Power Factor	Weight
64080-24VDC	Square Post Top Fixture	80	82	6,400	24	3.49	0.98	35 lbs
64100-24VDC	Square Post Top Fixture	100	105	8,000	24	4.37	0.98	35 lbs
64120-24VDC	Square Post Top Fixture	120	125	9,600	24	5.25	0.98	35 lbs
64150-24VDC	Square Post Top Fixture	150	158	12,000	24	6.56	0.98	35 lbs

SPECIFICATIONS

- Ballast Type Electronic
- Start Method InstantON
- Hot Re-start InstantON
- Input Line Voltage 24 VDC
- Input Line Frequency 50/60 Hz
- Lamp Operating Frequency 250 kHz
- Ballast Off-State Draw 0 Watts
- Sound Rating Class A
- Lamp / Ballast System Life 100,000 Hrs.
- Lumen Maintenance @75,000Hrs > 70%
- Color Temperature 5000°K
- Color Rendering Index (CRI) > 83
- Minimum Starting Temperature -20°F
- Maximum Starting Temperature 160°F
- Initial Lumens per Watt 80
- Shock / Vibration Resistant Yes
- Power Factor > 0.98
- ETL Listed / UL Standard 1598 Yes
- FCC Compliance Part 18, Subp. C
- EPA Rating 1.21
- IP Rating IP65
- Warranty 10 Year

MOUNTING OPTIONS

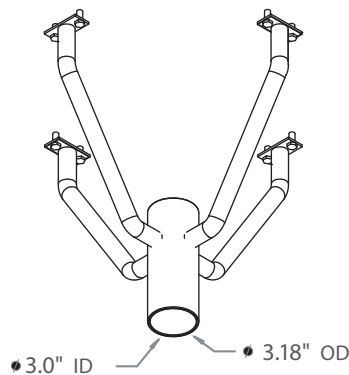

Accepts up to 2-7/8" Round Tenon or Pole

IOP-RPTR (contact factory)

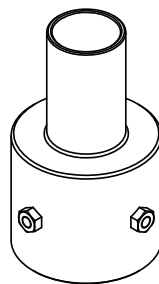

Round Pole Tenon Reducers available for 3", 4", & 5" O.D. Poles

PHOTOMETRICS (See Complete IES File)

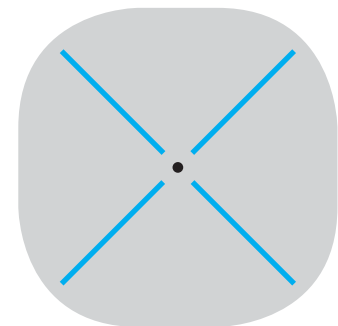

Type V Distribution

Neptun Light, Inc.
13950 Business Center Drive
Lake Forest, IL 60045
Fax: 847.735.8004

Neptun Light, Inc. reserves the right to change materials or modify the design of its product without notification as part of the company's continuing product improvement program.
©2002-2013 Neptun Light, Inc. All rights reserved.

Spec. Rev. 1-2013