

Incredible **100,000** hrs

GENERAL DESCRIPTION

Neptun's LED High-Mast fixture features classic form and durability to be used in new construction or retrofit applications. The LED-HM62 series fixture features excellent optics and its rugged design allows for use in a variety outdoor applications. It can replace existing HID & HPS fixtures up to 1500 Watts.

APPLICATION

- High-Mast Lighting
- Sports Field Lighting
- Yard Lighting
- Area & Storage Lighting

STRUCTURE, MATERIALS, & FEATURES

- Heavy-gauge, die-cast aluminum housing with cooling fins.
- Heat and impact resistant tempered glass lens with anti-glare diffuser.
- Continuous silicone gasket surrounds lens for weather - tight seal.
- Adjustable yoke mount or pole mount available.
- Instant-On flicker-free Cold Start and Hot Re-Start.
- LED engine design with Advanced Thermal Management.
- High Output LED's.
- High power factor, low THD driver with 6kV/3kA surge protection. Optional 20kV/10kA surge protector available.
- Up to 15 year maintenance free operation.
- 5 Year Warranty on complete fixture. (LED's, Driver, & Housing)
- **Optional:** 0-10V Dimming, Wi-Fi Control, Remote Monitoring and ON/ OFF Control

ORDERING INFORMATION

Sample Number: LED-HM62-500-UNV-0-10VDIM-YK-850-B25-LD
Custom options and accessories available. Please consult factory

Series	Wattage	Voltage	Options	Mounting	Color Temp	Optics	Accessories
LED-HM62 = High-Mast	500 = 500 W	UNV = 120-277 VAC 347V = 347 VAC 480V = 480 VAC	0-10VDIM = 0-10V Dimming * Contact Factory for dimming options.	YK = Adjustable Yoke PM = Pipe Mount ** ** Special Order	835 = 3500°K 841 = 4100°K 850 = 5000°K * * Standard	B25 = 25° Beam B45 = 45° Beam B60 = 60° Beam B90 = 90° Beam B100 = 100° Beam	LD = Twist-Lock Photocell SP = 20kV/10kA surge protector



lightinnovations@work™

PRODUCT INFORMATION

Model No.	Description	Rated Watts	Input Watts	Delivered Lumens	Universal Line Voltage (VAC)	Max Line Current (Amp) @ 120 - 277	THD	Power Factor	Weight
LED-HM62-500-UNV	High-Mast Fixture	500	502	45,000	120-277	4.37 - 1.89	<20%	>0.90	60 lbs

SPECIFICATIONS

- Driver Constant Current
- Start Method InstantON
- Hot Re-start InstantON
- Power Supply 350mA
- Driver UL Rating Class 1
- Driver UL Outdoor Rated Wet Location
- Sound Rating Class A
- ANSI Surge Protection IEEE C62.41 C High
- Current Crest Factor 1.5 maximum
- Load Regulation: 5% output current variation across load range
- Line Regulation: 1% output voltage variation across voltage range
- Driver Off-State Draw 0 Watts
- Vibration Compliance 3G
- Universal Input Line Voltage 120-277 VAC
- Input Line Frequency 50/60 Hz
- Projected (L70) @ 25°C > 100,000 hrs.
- Color Temperature 5,000°K
- Color Rendering Index (CRI) > 80
- Minimum Starting Temperature -40°C
- Maximum Starting Temperature +50°C
- Lumens per Watt > 90
- Shock / Vibration Resistant Yes
- Power Factor > 0.90
- Total Harmonic Distortion < 20%
- Inrush Current Peak < 10 Amp
- FCC Compliance Part 15, Subp. C
- EPA Rating 2.47 ft.²
- Housing IP Rating IP65
- Driver IP Rating IP67
- Optics IP Rating IP65
- Warranty 5 Year

MOUNTING OPTIONS

216° ADJUSTABLE
YOKE BRACKET

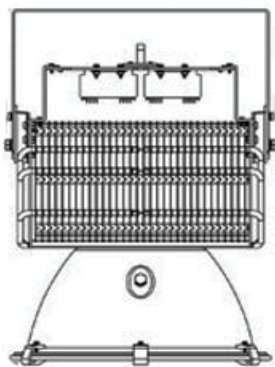

Pipe mount
(Accepts up to 2-3/8"
Round tenon or pipe)

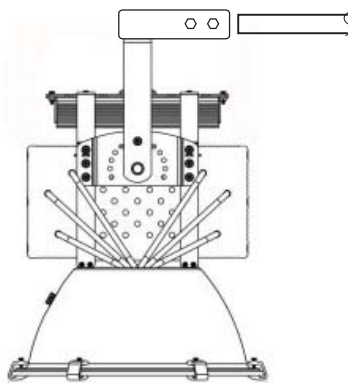

PHOTOMETRICS (See Complete IES File)

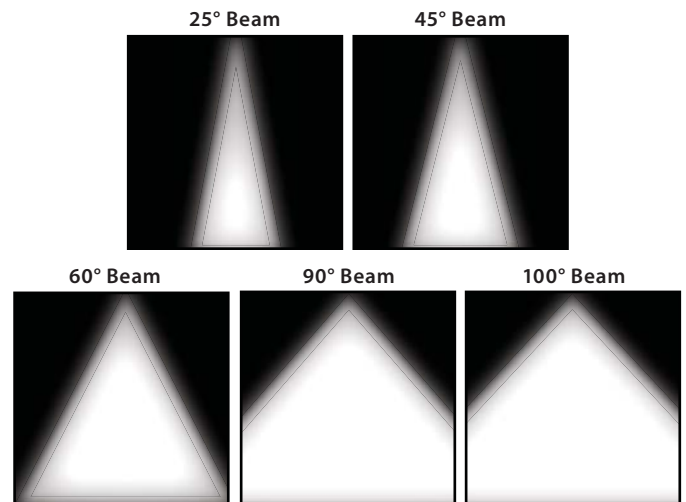

Neptun Light, Inc.
13950 Business Center Drive
Lake Forest, IL 60045
Fax: 847.735.8004

Neptun Light, Inc. reserves the right to change materials or modify the design of its product without notification as part of the company's continuing product improvement program.
©2002-2016 Neptun Light, Inc. All rights reserved.

Spec. Rev. 7-2016