

Incredible **100,000 hrs**

### GENERAL DESCRIPTION

Neptun's Induction 20" Aluminum High / Low-Bay fixtures combine architectural design and versatility to make it an excellent choice for new construction or retrofit applications. The 20" housing is offered in a variety of wattages to provide maximum flexibility in all types of applications. It can replace existing HID & HPS fixtures up to 400W.

### APPLICATION

- Warehouse Lighting
- Factory Lighting
- Retail Lighting
- Showroom Lighting
- Grocery Store Lighting
- Area & Storage Lighting
- Gymnasium Lighting

### STRUCTURE, MATERIALS, & FEATURES

- 20" high reflectance Aluminum hood.
- Corrosion resistant die-cast aluminum gear box with white electrocoat finish.
- Inductively coupled circular induction bulb.
- High power factor, low THD electronic ballast with surge protection.
- Instant-On flicker-free Cold Start and Hot Re-Start.
- High quality glare-free light with high CRI above (83).
- Bright white light (5000°K) for greater visibility and safety.
- Advance phosphors for high lumen output and high lumen maintenance.
- Up to 20 year maintenance free operation.
- 10 Year Warranty.

### ORDERING INFORMATION

Sample Number: 172120-AL-UNV-850-MD-C3  
 Custom options and accessories available. Please consult factory

Series	Wattage	Reflector	Voltage	Color Temp	Accessories	Options
172 = 20" Low-Bay	100 = 100 W 120 = 120 W 150 = 150 W 200 = 200 W 250 = 250 W	AL = Aluminum	UNV = 120-277 VAC 347V = 347 VAC 480V = 480 VAC	830 = 3000°K 841 = 4100°K 850 = 5000°K * * Standard	MD = Motion Detector	C3* = 3' Cord-No Plug (other lengths available by specifying cord length C6 = 6' cord) PC3 = 3' Cord with NEMA Plug (verify plug type when ordering) * Standard



lightinnovations@work™

### PRODUCT INFORMATION

Model No.	Description	Rated Watts	Input Watts	Initial Lumens	Universal Line Voltage (VAC)	Max Line Current (Amp) @ 120 - 277	THD	Power Factor	Weight
172100-AL-UNV	20" High/Low-Bay Fixture	100	105	8,000	120-277	0.87 - 0.36	<10%	0.98	20 lbs
172120-AL-UNV	20" High/Low-Bay Fixture	120	125	9,600	120-277	1.05 - 0.45	<10%	0.98	20 lbs
172150-AL-UNV	20" High/Low-Bay Fixture	150	158	12,000	120-277	1.31 - 0.56	<10%	0.98	20 lbs
172200-AL-UNV	20" High/Low-Bay Fixture	200	210	16,000	120-277	1.75 - 0.75	<10%	0.98	20 lbs
172250-AL-UNV	20" High/Low-Bay Fixture	250	262	20,000	120-277	2.18 - 0.94	<10%	0.98	20 lbs

### SPECIFICATIONS

- Ballast Type ..... Electronic
- Start Method ..... InstantON
- Hot Re-start ..... InstantON
- Universal Input Line Voltage ..... 120-277 VAC
- Input Line Frequency ..... 50/60 Hz
- Lamp Operating Frequency ..... 250 kHz
- Ballast Off-State Draw ..... 0 Watts
- Sound Rating ..... Class A
- ANSI Surge Protection ..... Class A
- Lamp / Ballast System Life ..... 100,000 Hrs.
- Lumen Maintenance @75,000Hrs ..... > 70%
- Color Temperature ..... 5000°K
- Color Rendering Index (CRI) ..... 83
- Minimum Starting Temperature ..... -20°F
- Maximum Starting Temperature ..... 160°F
- Lumens per Watt ..... 80
- Sound Rating ..... Class A
- Power Factor ..... > 0.98
- Total Harmonic Distortion ..... < 10%
- Inrush Current Peak ..... < 10 Amp
- ETL Listed / UL Standard 1598 ..... Yes
- FCC Compliance ..... Part 18, Subp. C
- IP Rating ..... IP43
- Warranty ..... 10 Year

### MOUNTING OPTIONS

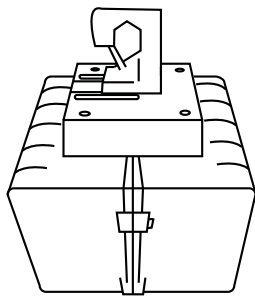

Hook Mount (Standard)

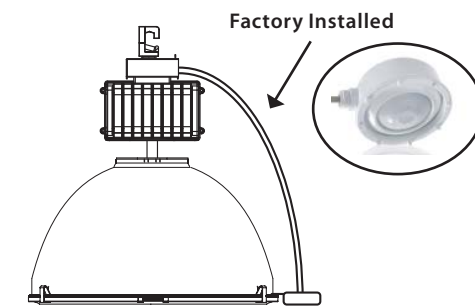

Motion Sensor (MD)  
Day Light Harvest Sensor (DLH)

### PHOTOMETRICS (See Complete IES File)

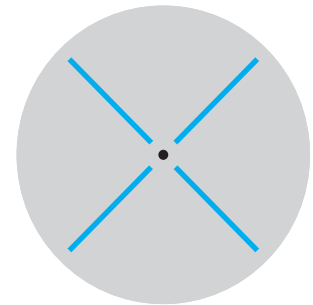

Type V Distribution

Neptun Light, Inc.  
13950 Business Center Drive  
Lake Forest, IL 60045  
Fax: 847.735.8004

Neptun Light, Inc. reserves the right to change materials or modify the design of its product without notification as part of the company's continuing product improvement program.  
©2002-2016 Neptun Light, Inc. All rights reserved. Spec. Rev. 4-2016